



A brand of  **legrand**[®]

SERENE DC CEILING FANS 4 BLADES

Instruction Manual



A brand of **legrand**

Serene DC Ceiling Fans 4 Blades

Cat. No: CF12DC4BWE, CF13DC4BWE

Instruction Manual

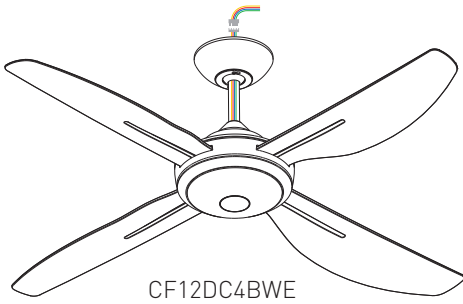

CF12DC4BWE

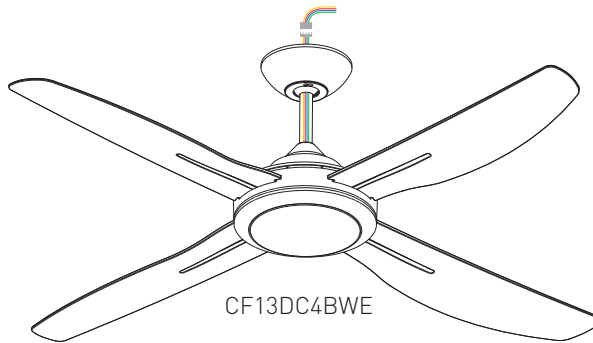

CF13DC4BWE



WARNING: THIS PRODUCT MUST BE INSTALLED BY A LICENSED ELECTRICIAN

PLEASE READ ALL INSTRUCTIONS CAREFULLY. RETAIN FOR FUTURE REFERENCE.

Product Specifications		
	CF12DC4BWE	CF13DC4BWE
Supply Voltage	230-240 V ~ 50 Hz	
Power (Motor)	40 W	
Maximum Airflow	11,400 m ³ /h	12,600 m ³ /h
Product Weight	6.0 kgs	6.4 kgs
Fan Size	1220 mm, 48"	1320 mm, 52"
Power Factor	0.55 @ 240 V a.c. 50 Hz	

Box contents

- Motor assembly (x1)
- ABS plastic blades (x4)
- Blade screws (x9)
- Mounting bracket (x1)
- Mounting bracket screw (x2) (Timber use only)
- Plastic anchors (x2)
- Remote control with 2 x AAA battery and screws (x1)
- Remote control holder (x1)

IMPORTANT CONSIDERATIONS

1. The hangsure style is suitable for both flat and inclined ceilings (up to maximum angle of 13°).
2. This fan has been supplied with a 6 speed fan control. It is designed to operate a single fan only.
3. The fan is to be installed so that the fan blades are more than 2.1m above floor level. Fan blades should have clearances >300mm from any obstacles.
4. During installation a switch disconnection should be incorporated in the supply circuit.
5. Blades provided are paired for individual fan and must not be mixed with blades from other fans. This may affect performance and cause vibration/wobble. If unusual oscillating movement is observed, stop using the ceiling fan immediately and contact Legrand Australia, its service agent or a suitably qualified person.

1 QUICK-FIT BLADE INSTALLATION

A. Turn the top motor housing anticlockwise and lift upward.

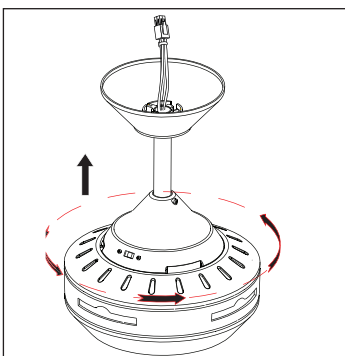

B. Insert the blade into the rectangular slot on the side of the motor body.

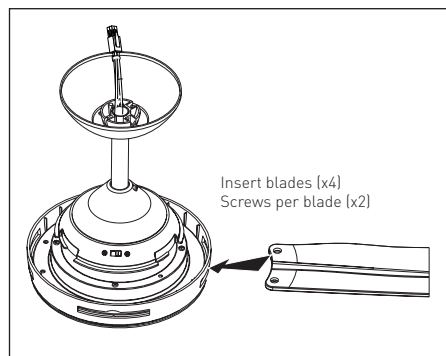

C. Tighten screws provided in kit. Refit the top motor housing to the fan body by reversing step 1.

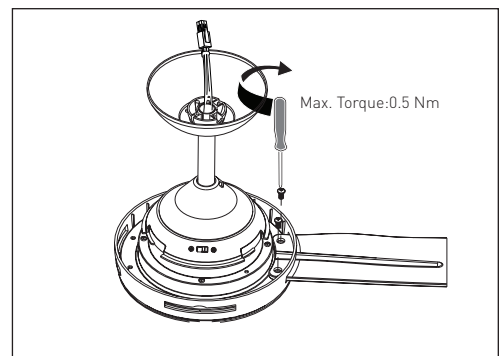

Note: Make sure that the blades are oriented as shown above and ensure the top motor housing has locked back into place.

2 FIXING THE MOUNTING BRACKET TO CEILING

Select a suitable location for the fan. Use the 2 coach screws provided (or similar) to make an attachment to a solid structural member. Ensure the mounting method is capable of supporting a hanging weight of 30 kg.

Fix mounting bracket (supplied) firmly to timber or concrete.

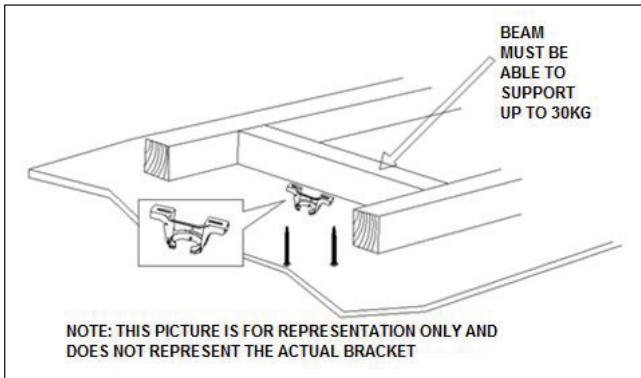

Angled Ceiling Installation

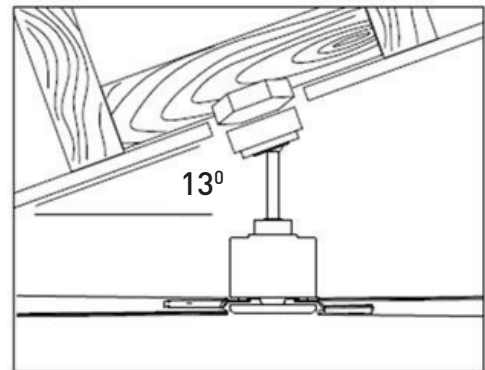

This fan hanging system supports a maximum 13° angled ceiling installation.

Warning: Ceiling fan must be mounted so that blades are 2.1m from the floor and 300mm from the wall and other obstructions to the blade tip.

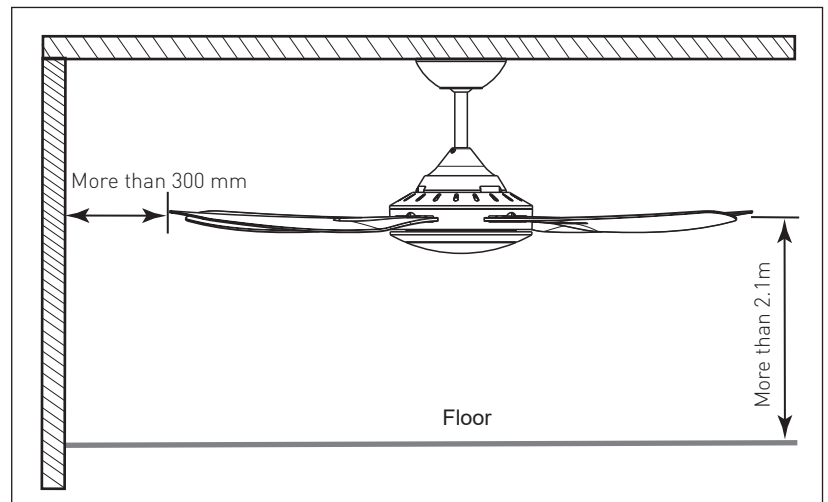

3 WIRING

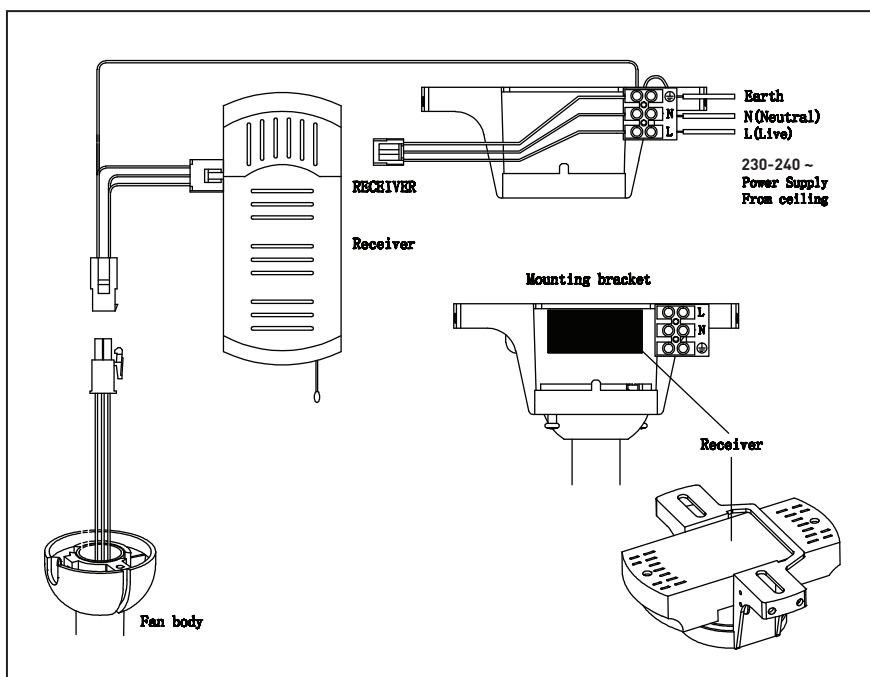

1. Connect the mains power supply to the terminal block (A). Live to "L" terminal, Neutral to "N" terminal Earth to "⊕" terminal. Ensure the wires are secure and no bare wires are exposed.
2. Insert the DC remote receiver into the mounting bracket.
3. Insert the 3-port fixed wire quick connector to the receiver power input socket.
4. Insert the DC remote receiver output wire connector to the receiver power output socket.
5. Join the receiver output wire and the motor power input wire together via the 4-port quick connectors.

4 POWER SUPPLY CONNECTION TO THE TERMINAL BLOCK

A. Connect supply wiring to the terminal block provided in hanging bracket.

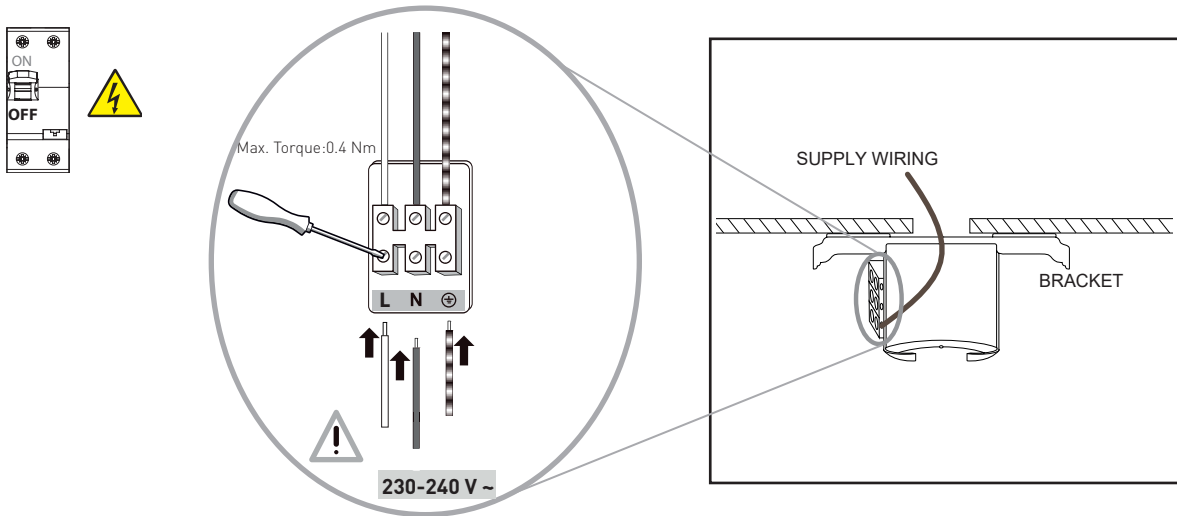

5 HANGING THE FAN ON THE BRACKET

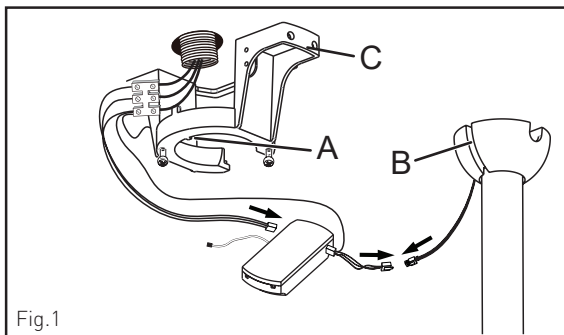

- After completing the electrical connection at the mounting bracket terminal block, connect the ceiling fan by joining the male and female connector plugs.
- Ensure slot (B) of the hanging ball joint is positioned on notch (A) of the mounting bracket (C) to prevent the fan from rotating when in operation (See Fig.1).

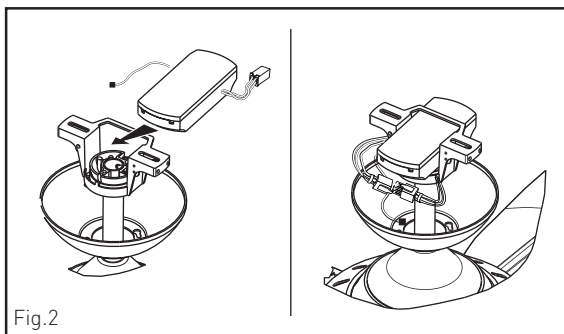

- Place the remote receiver assembly onto the mounting bracket.

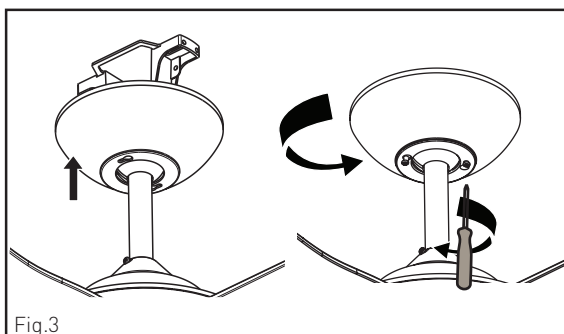

- Cover the mounting bracket with the canopy. Ensure all electrical wiring is tucked inside the canopy and that the wires are not damaged during this step.
- Secure the canopy to the mounting bracket using the screws provided (See Fig.2).

6 REMOTE CONTROL

a. Fan OFF button

- Press the button to turn the fan OFF.
- Press and hold the button for 5 seconds within 30 seconds of switching the power to the receiver for pairing the transmitter and receiver.

b. Fan speed control button

Press the speed buttons from 6 to 1, the fan will run from Extra-high speed (6) to Extra-low speed (1).

c. No function

d. Natural wind button

- Press the button to activate the natural wind mode.
- Press any speed control button to exit the natural wind mode

Note: Natural wind mode changes the fan speed from 1 to 6 in 20 sec intervals creating a wind effect.

e. Forward/Reverse button (Only on the remote not on body)

Press the button to activate the reverse running function. The fan must be operating to activate the reverse function. Press again to return to the forward running function.

f. Timer control button

Press the button to activate the fan timer function, the fan will turn OFF after running 1 hour / 4 hours / 8 hours. To cancel the timer function, just press the fan OFF button.

g. Batteries (2 x AAA 1.5V) supplied.

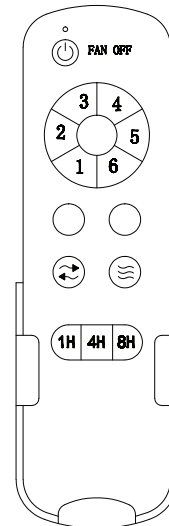

Battery Installation

- 2 x AAA 1.5 V batteries are used to operate the remote control.
- Loosen the screw from the battery cover.
- Pull out the battery cover and install the batteries.
- Ensure the polarity is correct as shown in the battery compartment.
- Please remove the batteries if you intend not using the ceiling fan for any long periods of time.

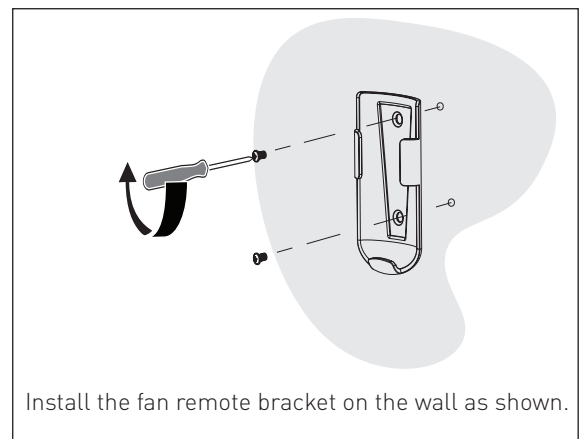

7 PAIRING THE SPEED CONTROLLER

The remote and receiver have already been paired during manufacturing. When the ceiling fan is installed for the first time, pairing of the remote and receiver is NOT required. If the remote and receiver lose pairing after installation or during use, the remote and the receiver must be re-paired. The scenario and method to re-pair the pairing of the DC ceiling fan remote and receiver are below.

Issues:

- Loss of control - Fan is only running at high speed after installation
- Loss of control - No reverse function after installation
- Loss of control - Remote cannot communicate with the receiver

Solution:

- Switch OFF the main power to ceiling fan.
- Press and hold the **"FAN OFF"** button on the remote for 5 seconds (within 30 seconds of switching the power ON to the receiver of the ceiling fan). A long "beep" sound to indicate the pairing process is activated. Release your finger from the power button.
- After waiting 2-3 minutes, turn the fan ON and change the speed of the ceiling fan by the remote to check the operation and successful pairing.

Downrods

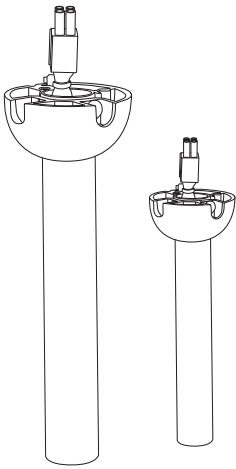

Serene Ceiling Fan Extension Downrod
750 mm x 21.5 mm-White
(CFSERDR750WE)

Serene Ceiling Fan Extension Downrod
1500 mm x 21.5 mm-White
(CFSERDR1500WE)

9 DOWNROD INSTALLATION

REMOVING THE ROD

Warning: Ceiling fan must be mounted so that blades are 2.1m from the floor and 300mm from the wall and other obstructions to the blade tip (Refer to Section 2. Fixing the mounting bracket to ceiling on page 2).

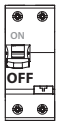

DURING WIRING

Make sure the power is switched off during installation.

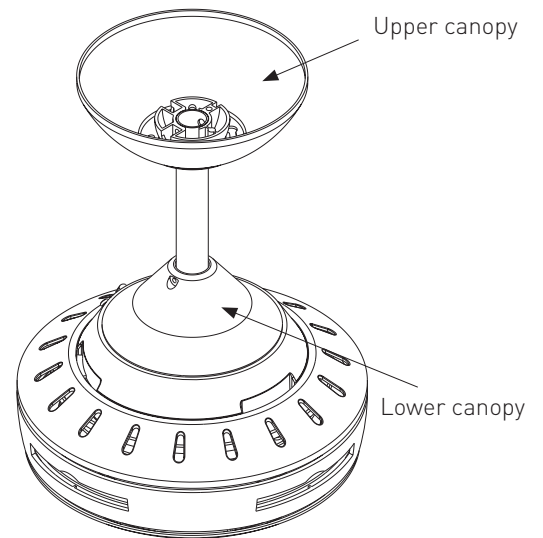
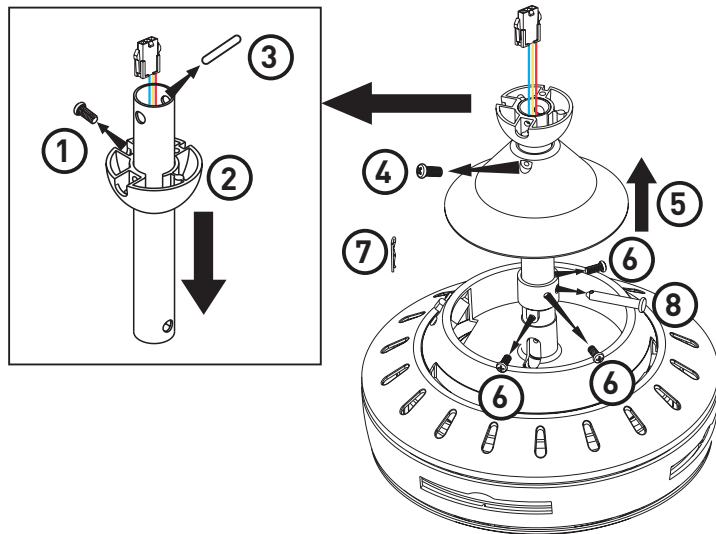

- a. Lower the upper canopy.
- b. Unscrew the screw (1) and lower the hanging ball (2).
- c. Take out the clevis pin (3).
- d. Unscrew the screw (4) and lift the lower canopy up (5).
- e. Unscrew the screws (6) on the lower joint of downrod and take the r-clip (7) out.
- f. Remove the clevis pin (8).
- g. Detach the downrod and take the connector wire out.

REPLACING WITH DOWNROD

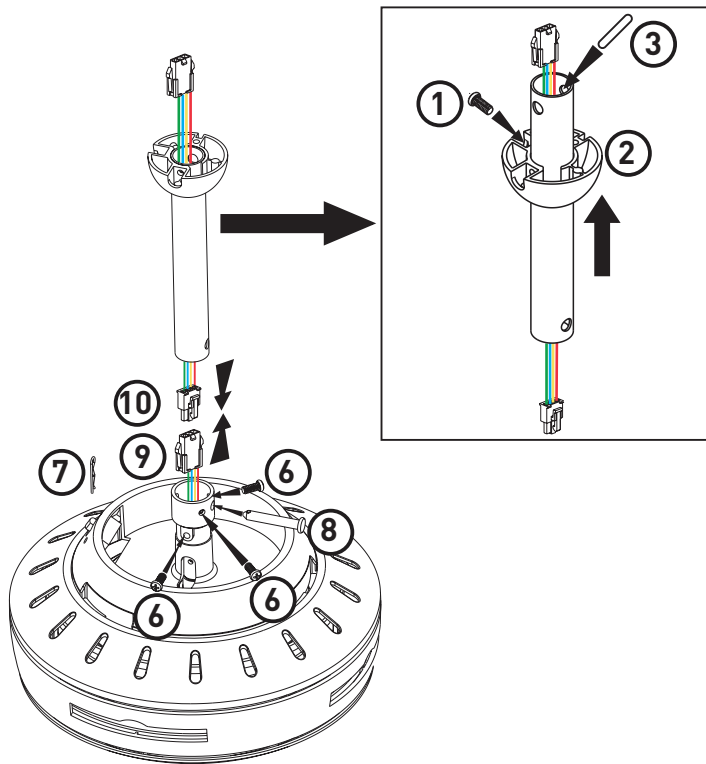

Note: Max. Torque: 0.4 Nm for all screws.

- Assemble the upper and lower canopy onto the new downrod.
- Connect the male (10) to the female (9) connector at the bottom of the downrod and pull the wire from the top of downrod.
- Assemble the downrod in place with all the screws (6), clevis pins (3,8) and r-clip (7).
- Ensure both clevis pins (3,8) are secure and all screws are tightened.
- Place the hanging ball (2) into position and tighten the screw (1).
- Set the lower and upper canopy onto downroad and tighten the screw (4).

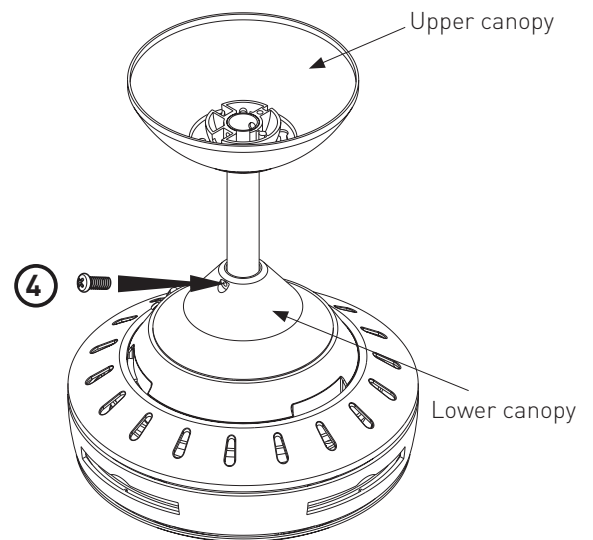

PRODUCT NOTES

- This product must be installed by a licensed electrician and used as per these instructions.
- This product contains no serviceable parts and no attempt should be made to repair this product. If the product is faulty it should be discarded.
- This product must be cleaned periodically with a damp cloth. Cleaning agents and solvents should never be used.
- This product has been designed to operate in ambient temperatures between 5°C to 40°C.
- This product must be securely attached to a structural member for support. Fixing means (brackets) must be fixed to the structural member with sufficient strength to withstand 4 times the weight of the ceiling fan.
- During installation the mains supply wiring terminals should be tightened between 0.4Nm and 0.6Nm. Over-tightening may damage the terminal. Under-tightening may result in hot joints.
- This product is not intended to be exposed to direct weathering. It is not suitable for installation in hazardous and/or corrosive areas. It is not suitable for marine environments such as areas subjected to salt spray and/or mist.
- This product is not intended for use by young children or infirm persons without supervision. Young children should be supervised to ensure that they do not play with the appliance.
- Only those accessories as supplied by Legrand are designed for operation with the fan.
- Extended exposure to UV rays (such as exposure to direct sunlight) may cause discolouration of this product.
- The material in this product may vary in colour from batch to batch. Colour matching from one batch to another cannot be guaranteed.
- This product has been designed to operate on a nominal supply voltage of 230-240 V a.c. 50 Hz.
- After installation this product must be tested as required by the appropriate government and/or statutory regulations.
- Legrand reserves the right to modify the specification of this product at any time.

Warranty Statements

These goods come with guarantees that cannot be excluded under the Australian and New Zealand Consumer Laws. You are entitled to a replacement or a refund for a major failure and compensation for any other reasonably foreseeable loss or damage. You are also entitled to have the goods repaired or replaced if the goods fail to be of acceptable quality and the failure does not amount to a major failure.

- Legrand offers this product with a 6 year (2 year + 4 year) express warranty. . 6 year warranty doesn't apply to the remote control unit. The first 2 years are in-home whereas the following 4 years are parts only. To access this warranty please contact Legrand. The following conditions apply to this express warranty:
 - This warranty commences on the date of purchase.
 - Under no circumstances Legrand will be responsible for rectification or costs under this express warranty without prior written consent.
 - The product must be installed by a licenced electrician and in accordance with these installation instructions.
 - Minor vibration and variations between individual units is normal and not warrantable fault.
 - Humming or vibration caused by ripple control signals is not warrantable fault.
- Legrand ("we or us") has given each purchaser who is a consumer ("you") a warranty against defects in its products.
- As a consumer, you are entitled to the benefit of the Warranty and should read and understand its terms. In addition, for the purposes of the Australian and New Zealand Consumer Laws, we note the following:
 - If we accept your claim under the Warranty we will reimburse all your reasonable expenses in making and pursuing the claim, including the cost of reimbursement of any defective products returned in the ordinary course to us at the address above by post or other agreed means. Any such claim must be made within 14 days of your receiving notice of our acceptance of your claim and include any necessary supporting documentation or invoices.
 - As a consumer, you have rights under the Australian and New Zealand Consumer Laws and may have rights under other applicable laws which cannot be excluded, restricted or modified. Those rights are in addition to any rights you have under the Warranty.
- Our contact details for the purpose of any claims made under the Warranty are below. Any claim under the Warranty must be sent in writing to the following address:

AUSTRALIA ONLY

Legrand Australia Pty Ltd
Nexus Industry Park
Bldg 4, 43-47 Lyn Parade
PRESTONS, NSW 2170
1300 369 777
sales.orders@legrand.com.au

NEW ZEALAND ONLY

Legrand New Zealand Ltd
106-124 Target Rd
GLENFIELD, AUCKLAND
0800 476 009
nz.sales@legrand.co.nz